

CAN YOU SEE THE AIRPLANES? THE ADJACENT SAMPLES SHOW THREE DIFFERENT LEVELS OF SHADING. SETTINGS FOR VIEWING AND PRINTING DRAWING CONTENT ARE OPTIMIZED WHEN ALL THREE PLANES ARE VISIBLE. THIS GUIDANCE IS PROVIDED FOR REFERENCE ONLY.

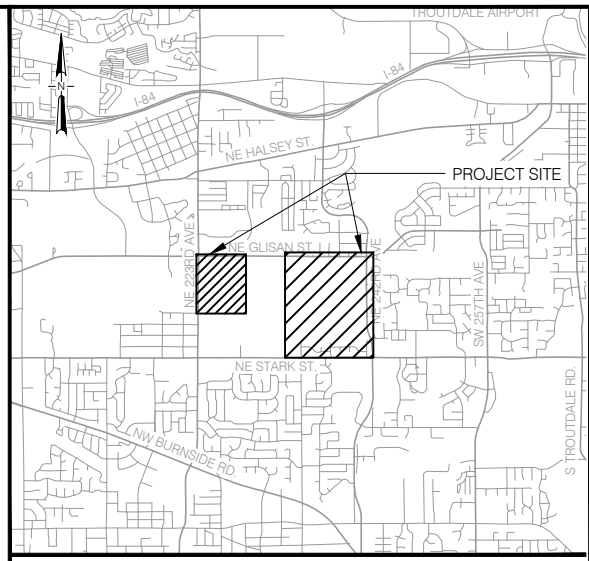
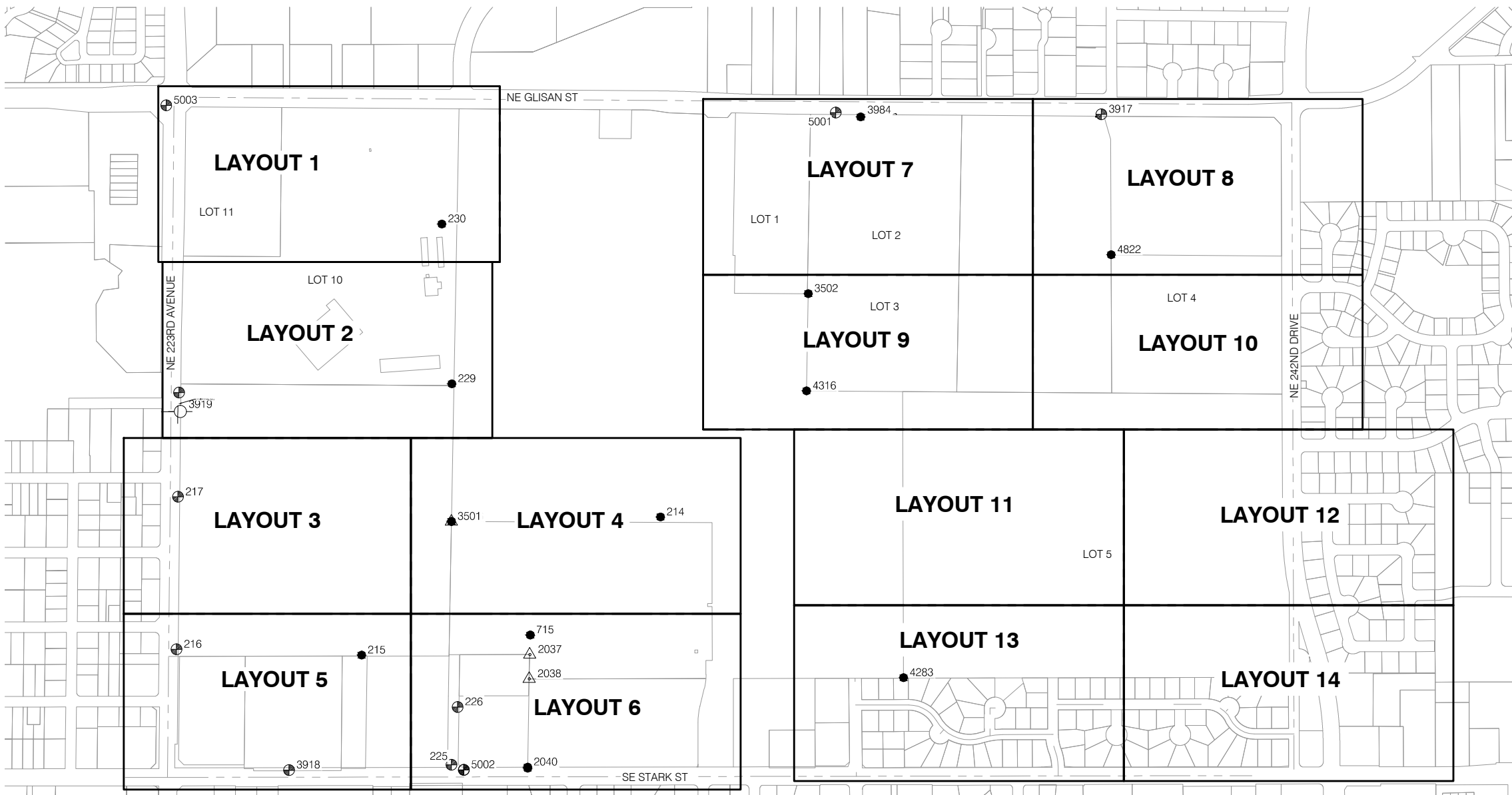
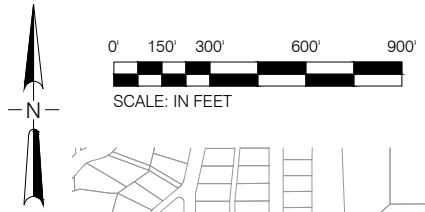

VICINITY MAP  
SCALE: N.T.S.

**LEGEND:**

|  |                                    |
|--|------------------------------------|
|  | FOUND IRON ROD                     |
|  | FLAG POLE                          |
|  | GATE POST                          |
|  | FENCE POST                         |
|  | FENCE LINE                         |
|  | GUARD POST                         |
|  | SIGN POST                          |
|  | DECIDUOUS TREE                     |
|  | EVERGREEN TREE                     |
|  | CATCH BASIN                        |
|  | CLEANOUT                           |
|  | CULVERT                            |
|  | MANHOLE                            |
|  | ROOF DRAIN                         |
|  | STORM OR SANITARY FLOW ARROW       |
|  | MANHOLE WITH SLOTTED GRATE         |
|  | OUTFALL                            |
|  | HOSE BIB                           |
|  | FIRE HYDRANT                       |
|  | METER                              |
|  | IRRIGATION CONTROL BOX             |
|  | GAS LINE MARKER                    |
|  | SIGNAL CONTROLLER                  |
|  | JUNCTION BOX                       |
|  | TRANSFORMER                        |
|  | UTILITY POLE                       |
|  | GUY ANCHOR                         |
|  | STREET LIGHTING (SINGLE LUMINAIRE) |
|  | STREET LIGHTING (DOUBLE LUMINAIRE) |
|  | STREET SIGNAL                      |
|  | VALVE                              |
|  | VAULT LID                          |

**NOTES:**

- HORIZONTAL DATUM IS BASED ON PORT OF PORTLAND LOCAL PROJECTION (INTERNATIONAL FEET). PER PORT OF PORTLAND DRAWING MD GVPB 2011-3024.
- VERTICAL DATUM BASED ON NGVD 29 (47).
- CONTOUR INTERVAL IS 1.0'.
- CALL-OUTS OF DIRECTIONS FOR STORM AND SANITARY SEWER PIPES ARE BASED ON TRUE NORTH (SEE NORTH ARROW).
- UTILITIES SHOWN ON THIS DRAWING DO NOT REPRESENT ALL UTILITIES IN THIS AREA. FOR A COMPLETE REPRESENTATION OF ALL KNOWN UTILITIES IN THIS AREA, CONTACT THE PORT OF PORTLAND ENGINEERING CAD DEPARTMENT. (503) 415-6341.
- SCREENED LINEWORK IS FOR BACKGROUND PURPOSES ONLY, AND HAS NOT BEEN SURVEYED.
- DETAILED TREE INFORMATION IS AVAILABLE IN PORT OF PORTLAND DRAWING GVPB 2012-8.

|  |                        |
|--|------------------------|
|  | EDGE OF PAVEMENT       |
|  | EDGE OF GRAVEL         |
|  | ELECTRICAL LINE        |
|  | OVERHEAD POWER LINE    |
|  | NATURAL GAS LINE       |
|  | SANITARY SEWER LINE    |
|  | STORM SEWER LINE       |
|  | TELEPHONE LINE         |
|  | COMMUNICATIONS LINE    |
|  | WATER LINE             |
|  | EXISTING MAJOR CONTOUR |
|  | EXISTING MINOR CONTOUR |

| NO. | DATE | BY | REVISIONS | APP'VD | CKD | NO. | DATE | BY | REVISIONS | APP'VD | CKD |
|-----|------|----|-----------|--------|-----|-----|------|----|-----------|--------|-----|
|     |      |    |           |        |     |     |      |    |           |        |     |



PORT OF PORTLAND  
PORTLAND, OREGON

2012UGEN DESIGN NUMBER      101743 PROJECT NUMBER

REGISTERED PROFESSIONAL LAND SURVEYOR

DESIGNED BY: C. VANDERWERF  
DRAWN BY: C. BIELANSKI / P. SHIELDS  
CHECKED BY: C. VANDERWERF  
DATE: SEP 2013  
SCALE: 1" = 300'

OREGON JULY 25, 1995  
CHRISTOPHER VANDERWERF 2719  
SIGNED: EXP: 6/30/2014

GRESHAM VISTA BUSINESS PARK

GVPB TOPOGRAPHIC SURVEY  
KEY PLAN, SURVEY CONTROL, & VICINITY MAP

SUBMITTED BY: ROBIN MCCAFFREY  
ENGINEERING PROJECT MANAGER

TYPE: TS  
DRAWING NO.: GVPB 2012-1  
1 / 18 (SU-1)

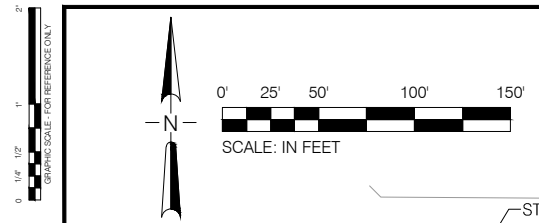

CAN YOU SEE THE AIRPLANES? THE ADJACENT SAMPLES SHOW THREE DIFFERENT LEVELS OF SHADING. SETTINGS FOR VIEWING AND PRINTING DRAWING CONTENT ARE OPTIMIZED WHEN ALL THREE PLANES ARE VISIBLE. THIS GUIDANCE IS PROVIDED FOR REFERENCE ONLY.

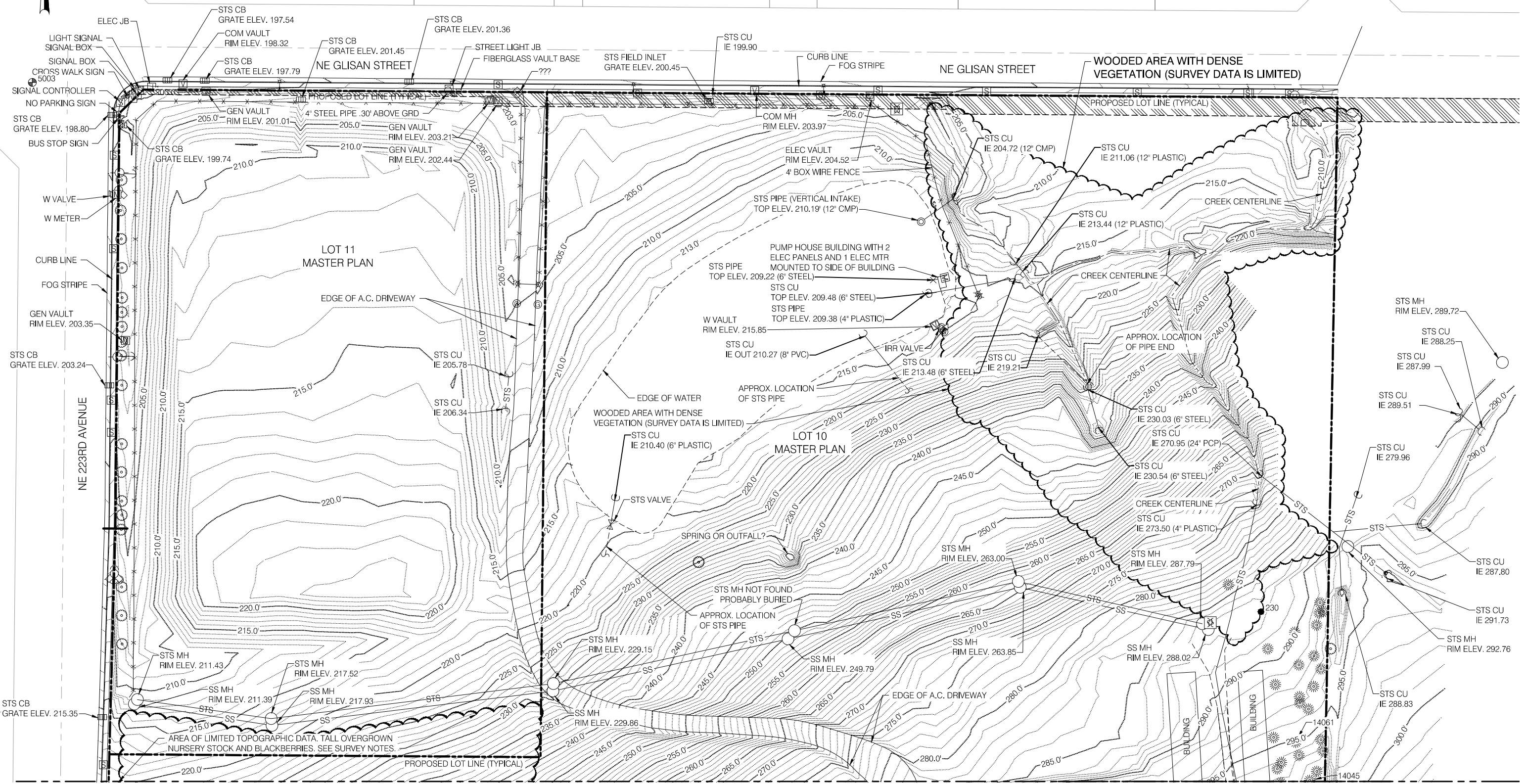

MATCH LINE - SEE SHEET SU-3

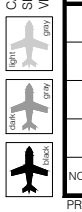

| NO. | DATE | BY | REVISIONS | APP'VD | CKD | NO. | DATE | BY | REVISIONS | APP'VD | CKD |
|-----|------|----|-----------|--------|-----|-----|------|----|-----------|--------|-----|
|     |      |    |           |        |     |     |      |    |           |        |     |



**PORT OF PORTLAND**  
PORTLAND, OREGON

2012UGEN  
DESIGN NUMBER

101743  
PROJECT NUMBER

REGISTERED PROFESSIONAL LAND SURVEYOR

OREGON  
JULY 25, 1995  
CHRISTOPHER VANDERWERF  
2719

SIGNED:  
EXP: 6/30/2014

DESIGNED BY: C. VANDERWERF  
DRAWN BY: C. BIELANSKI / P. SHIELDS  
CHECKED BY: C. VANDERWERF  
DATE: SEP 2013  
SCALE: 1" = 50'

**GRESHAM VISTA BUSINESS PARK**

**GVBV TOPOGRAPHIC SURVEY LAYOUT 1**

SUBMITTED BY: ROBIN MCCAFFREY  
ENGINEERING PROJECT MANAGER

TYPE: TS  
DRAWING NO.: GVBV 2012-1  
DATE: 2/18 (SU-2)

CAN YOU SEE THE AIRPLANES? THE ADJACENT SAMPLES SHOW THREE DIFFERENT LEVELS OF SHADING. SETTINGS FOR VIEWING AND PRINTING DRAWING CONTENT ARE OPTIMIZED WHEN ALL THREE PLANES ARE VISIBLE. THIS GUIDANCE IS PROVIDED FOR REFERENCE ONLY.

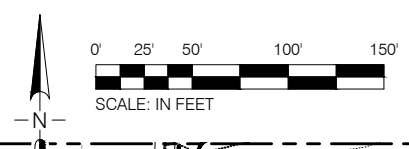

MATCH LINE - SEE SHEET SU-2

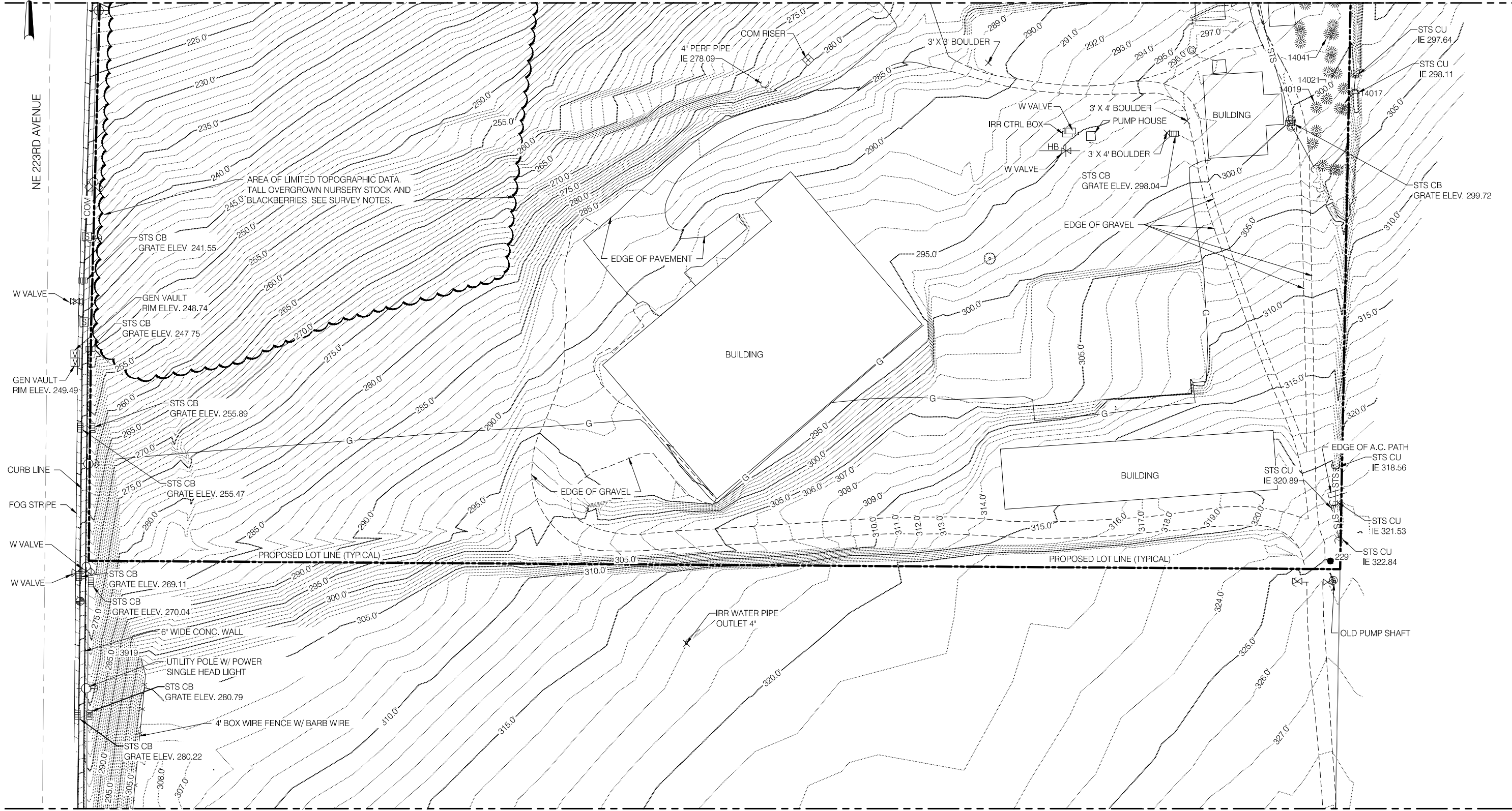

MATCH LINE - SEE SHEET SU-4

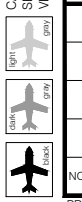

| NO. | DATE | BY | REVISIONS | APP'VD | CKD | NO. | DATE | BY | REVISIONS | APP'VD | CKD |
|-----|------|----|-----------|--------|-----|-----|------|----|-----------|--------|-----|
|     |      |    |           |        |     |     |      |    |           |        |     |

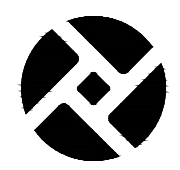

PORT OF PORTLAND  
PORTLAND, OREGON

REGISTERED PROFESSIONAL LAND SURVEYOR  
DESIGNED BY: C. VANDERWERF  
DRAWN BY: C. BIELANSKI / P. SHIELDS  
CHECKED BY: C. VANDERWERF  
DATE: SEP 2013  
SCALE: 1" = 50'

OREGON JULY 25, 1895  
CHRISTOPHER VANDERWERF 2719  
SIGNED: EXP: 6/30/2014

GRESHAM VISTA BUSINESS PARK

GVPB TOPOGRAPHIC SURVEY  
LAYOUT 2

SUBMITTED BY: ROBIN MCCAFFREY  
ENGINEERING PROJECT MANAGER

TYPE: TS  
DRAWING NO.: GVPB 2012-1  
DATE: 3/18 (SU-3)

0 1/4" = 1' (GRAPHIC SCALE - FOR REFERENCE ONLY)

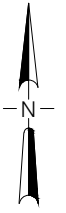

0' 25' 50' 100' 150'  
SCALE: IN FEET

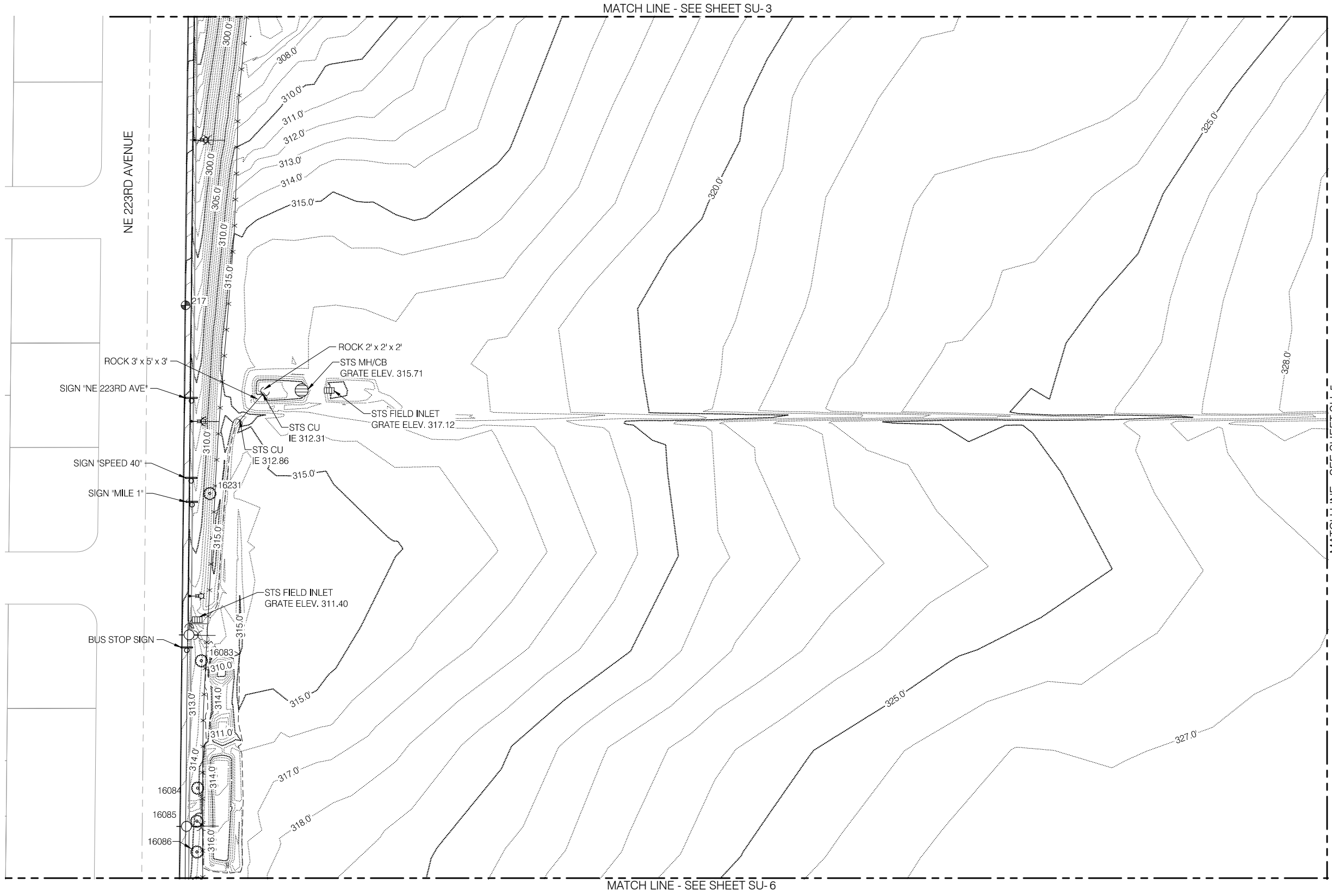

CAN YOU SEE THE AIRPLANES? THE ADJACENT SAMPLES SHOW THREE DIFFERENT LEVELS OF SHADING. SETTINGS FOR VIEWING AND PRINTING DRAWING CONTENT ARE OPTIMIZED WHEN ALL THREE PLANES ARE VISIBLE. THIS GUIDANCE IS PROVIDED FOR REFERENCE ONLY.

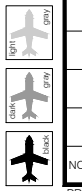

| NO. | DATE | BY | REVISIONS | APP'VD | CKD | NO. | DATE | BY | REVISIONS | APP'VD | CKD |
|-----|------|----|-----------|--------|-----|-----|------|----|-----------|--------|-----|
|     |      |    |           |        |     |     |      |    |           |        |     |



PORT OF PORTLAND  
PORTLAND, OREGON

2012UGEN 101743  
DESIGN NUMBER PROJECT NUMBER

REGISTERED  
PROFESSIONAL  
LAND SURVEYOR

OREGON  
JULY 25, 1995  
CHRISTOPHER VANDERWERF  
2719

SIGNED:  
EXP: 6/30/2014

DESIGNED BY C. VANDERWERF  
DRAWN BY C. BIELANSKI / P. SHIELDS  
CHECKED BY C. VANDERWERF  
DATE SEP 2013  
SCALE 1" = 50'

GRESHAM VISTA BUSINESS PARK

GVBP TOPOGRAPHIC SURVEY  
LAYOUT 3

SUBMITTED BY  
ROBIN MCCAFFREY  
ENGINEERING PROJECT MANAGER

TYPE TS DRAWING NO. GVBP 2012-1 4/18 (SU-4)



DRAWING SCALE: PART REFERENCE ONLY

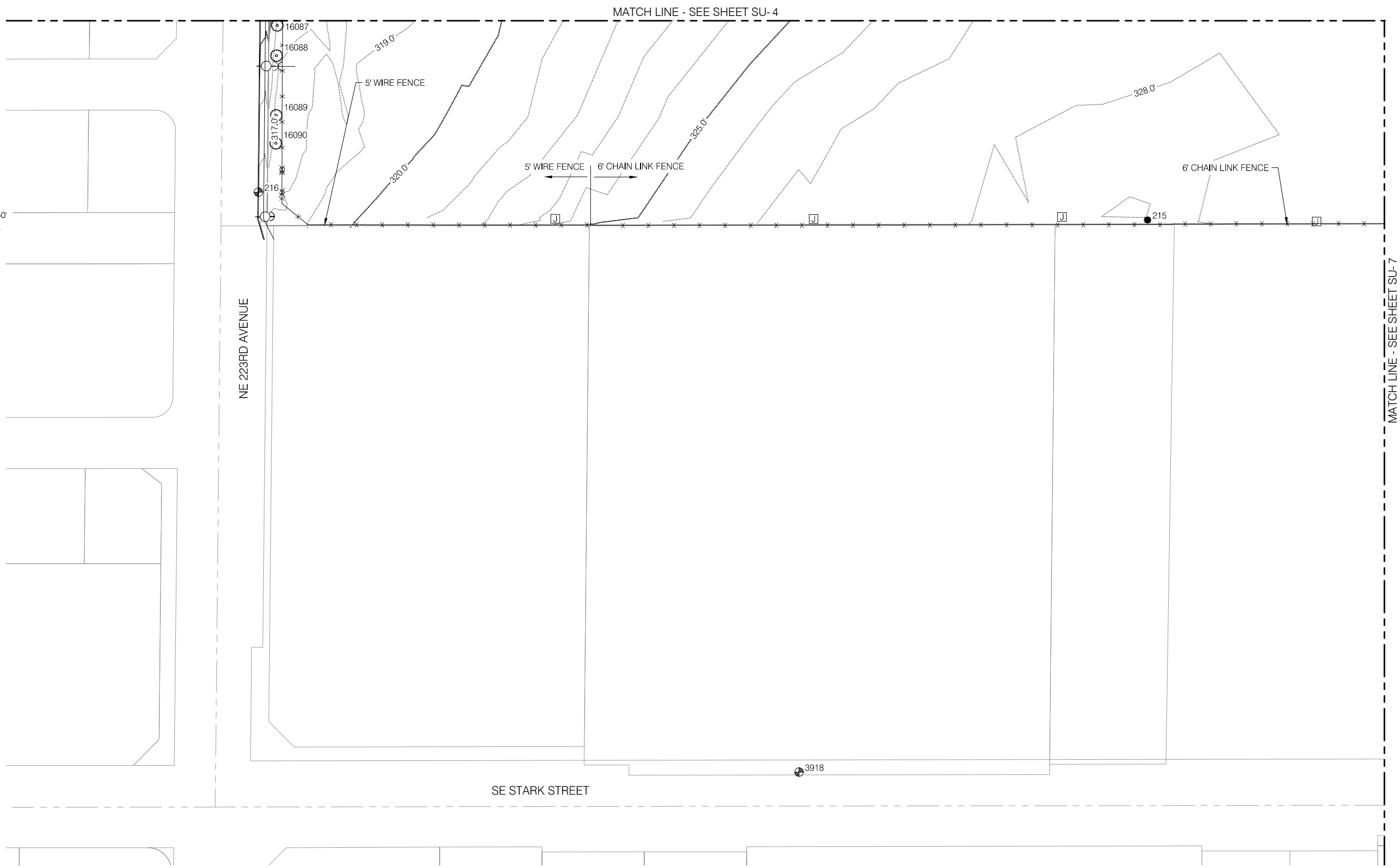
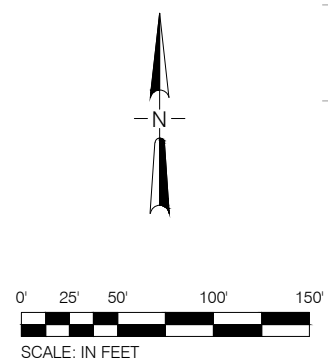

CAN YOU SEE THE AIRPLANES? THE ADJACENT SAMPLES SHOW THREE DIFFERENT LEVELS OF SHADING. SETTINGS FOR VIEWING AND PRINTING DRAWING CONTENT ARE OPTIMIZED WHEN ALL THREE PLANES ARE VISIBLE. THIS GUIDANCE IS PROVIDED FOR REFERENCE ONLY.

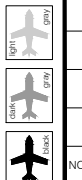

| NO. | DATE | BY | REVISIONS | APP'VD | CKD | NO. | DATE | BY | REVISIONS | APP'VD | CKD |
|-----|------|----|-----------|--------|-----|-----|------|----|-----------|--------|-----|
|     |      |    |           |        |     |     |      |    |           |        |     |



**PORT OF PORTLAND**  
PORTLAND, OREGON

2012UGEN  
DESIGN NUMBER

101743  
PROJECT NUMBER

REGISTERED  
PROFESSIONAL  
LAND SURVEYOR

DESIGNED BY C. VANDERWERF

DRAWN BY C. BIELANSKI / P. SHIELDS

CHECKED BY C. VANDERWERF

DATE SEP 2013

SCALE 1" = 50'

OREGON  
JULY 25, 1995  
CHRISTOPHER VANDERWERF  
2719

SIGNED:  
EXP: 6/30/2014

**GRESHAM VISTA BUSINESS PARK**

**GVBP TOPOGRAPHIC SURVEY  
LAYOUT 5**

SUBMITTED BY ROBIN MCCAFFREY  
ENGINEERING PROJECT MANAGER

TYPE TS DRAWING NO. GVBP 2012-1

6/18 (SU-6)

0 1/4" = 1' SCALE: IN FEET  
 (GRAPHIC SCALE: PART REFERENCE ONLY)

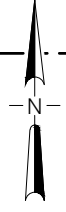

MATCH LINE - SEE SHEET SU-5

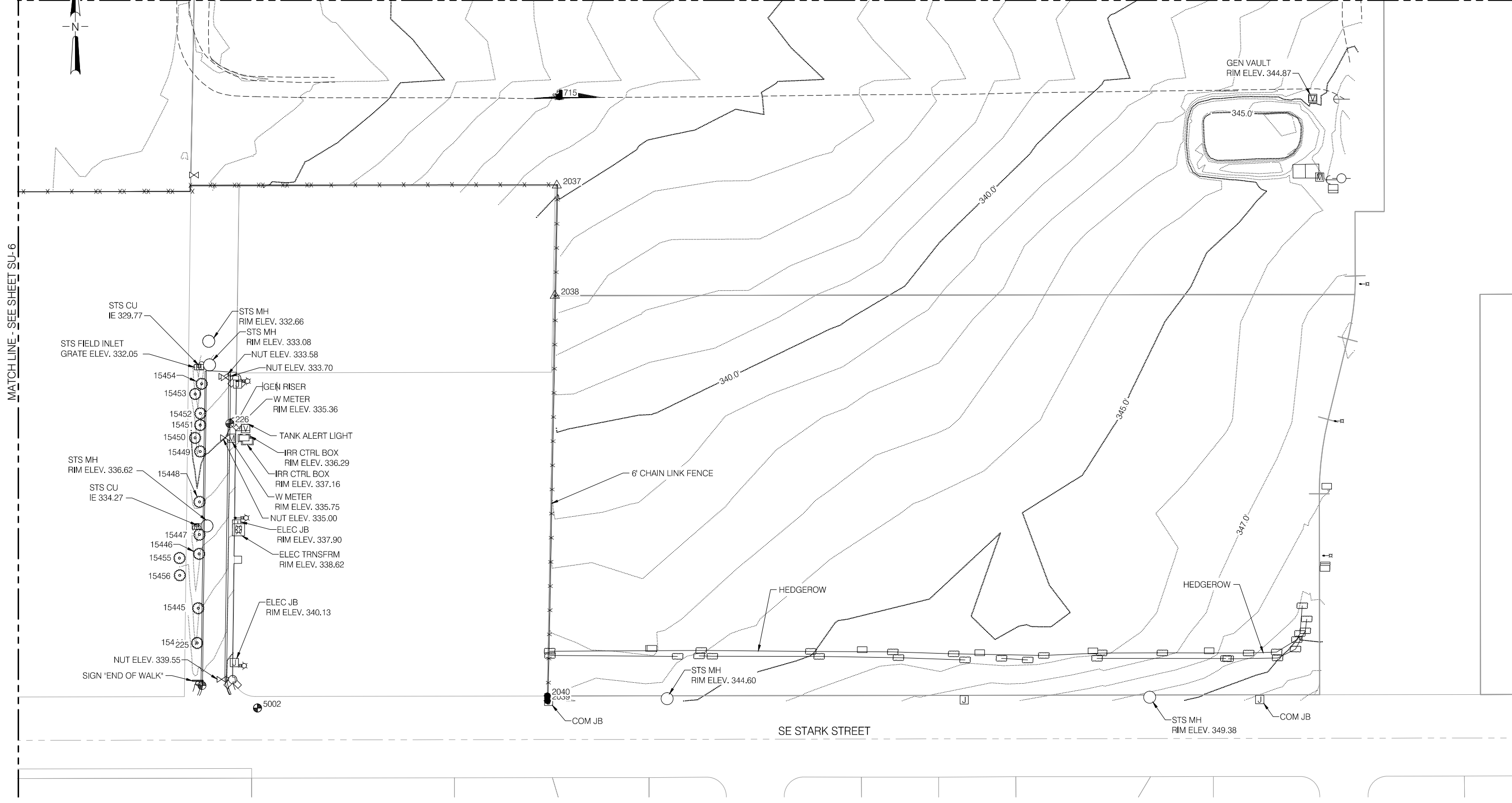

CAN YOU SEE THE AIRPLANES? THE ADJACENT SAMPLES SHOW THREE DIFFERENT LEVELS OF SHADING. SETTINGS FOR VIEWING AND PRINTING DRAWING CONTENT ARE OPTIMIZED WHEN ALL THREE PLANES ARE VISIBLE. THIS GUIDANCE IS PROVIDED FOR REFERENCE ONLY.

MATCH LINE - SEE SHEET SU-6

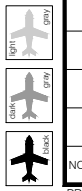

| NO. | DATE | BY | REVISIONS | APP'VD | CKD | NO. | DATE | BY | REVISIONS | APP'VD | CKD |
|-----|------|----|-----------|--------|-----|-----|------|----|-----------|--------|-----|
|     |      |    |           |        |     |     |      |    |           |        |     |



PORT OF PORTLAND  
PORTLAND, OREGON

2012UGEN DESIGN NUMBER      101743 PROJECT NUMBER

REGISTERED PROFESSIONAL LAND SURVEYOR

OREGON JULY 25, 1995  
CHRISTOPHER VANDERWERF 2719  
SIGNED: EXP: 6/30/2014

DESIGNED BY: C. VANDERWERF  
DRAWN BY: C. BIELANSKI / P. SHIELDS  
CHECKED BY: C. VANDERWERF  
DATE: SEP 2013  
SCALE: 1" = 50'

GRESHAM VISTA BUSINESS PARK

GVBP TOPOGRAPHIC SURVEY  
LAYOUT 6

SUBMITTED BY: ROBIN MCCAFFREY  
ENGINEERING PROJECT MANAGER

TYPE: TS      DRAWING NO.: GVBP 2012-1      7/18 (SU-7)

CAN YOU SEE THE AIRPLANES? THE ADJACENT SAMPLES SHOW THREE DIFFERENT LEVELS OF SHADING. SETTINGS FOR VIEWING AND PRINTING AND DRAWING CONTENT ARE OPTIMIZED WHEN ALL THREE PLANES ARE VISIBLE. THIS GUIDANCE IS PROVIDED FOR REFERENCE ONLY.

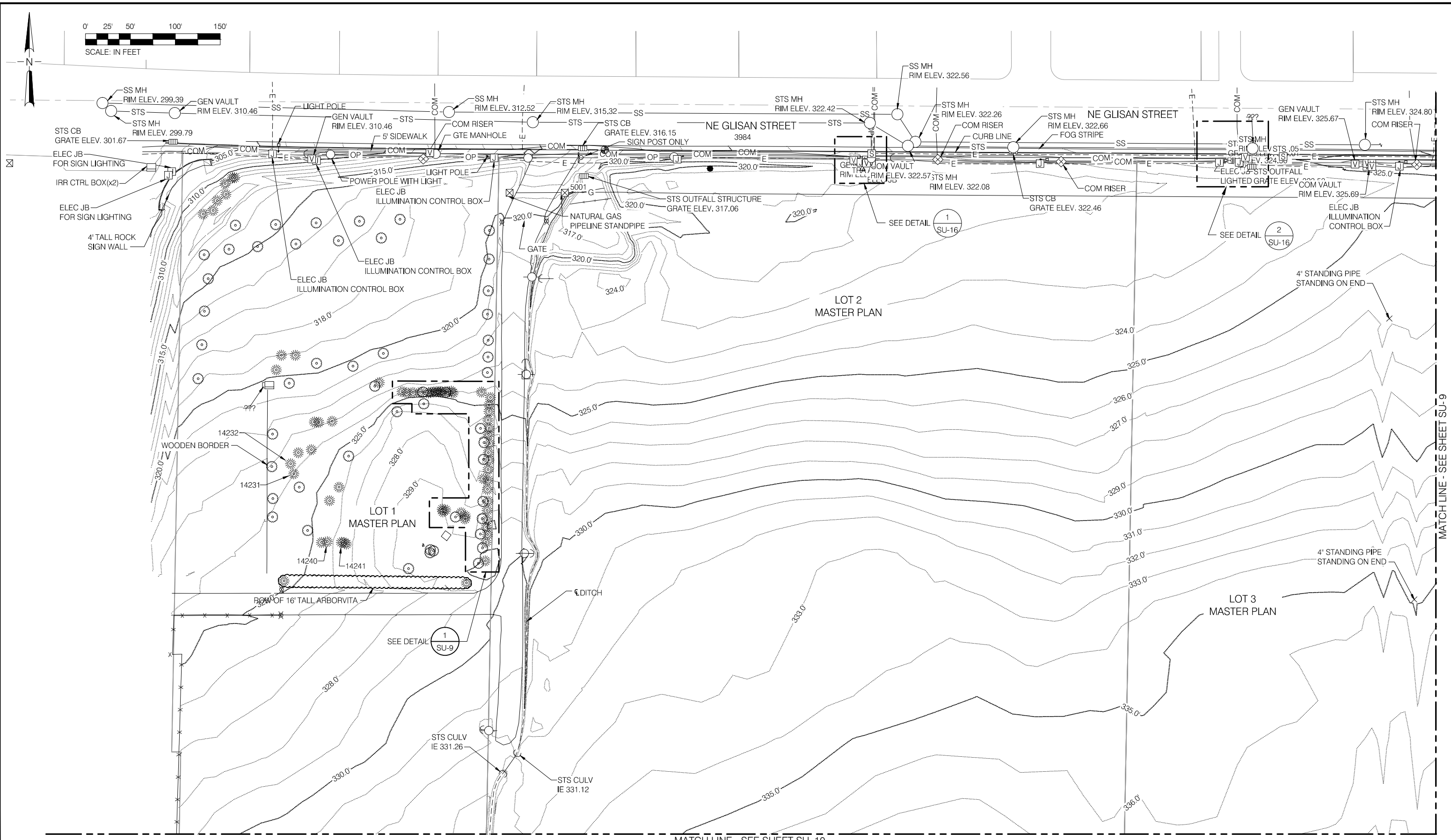
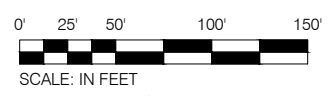

| NO. | DATE | BY | REVISIONS | APP'VD | CKD | NO. | DATE | BY | REVISIONS | APP'VD | CKD |
|-----|------|----|-----------|--------|-----|-----|------|----|-----------|--------|-----|
|     |      |    |           |        |     |     |      |    |           |        |     |



**PORT OF PORTLAND**  
PORTLAND, OREGON

2012UGEN  
DESIGN NUMBER

101743  
PROJECT NUMBER

REGISTERED PROFESSIONAL LAND SURVEYOR

DESIGNED BY: C. VANDERWERF  
DRAWN BY: C. BIELANSKI / P. SHIELDS  
CHECKED BY: C. VANDERWERF  
DATE: SEP 2013  
SCALE: 1" = 50'

OREGON JULY 25, 1995  
CHRISTOPHER VANDERWERF 2719  
SIGNED: EXP: 6/30/2014

**GRESHAM VISTA BUSINESS PARK**

**GVBV TOPOGRAPHIC SURVEY LAYOUT 7**

SUBMITTED BY: ROBIN MCCAFFREY  
ENGINEERING PROJECT MANAGER

TYPE: TS  
DRAWING NO.: GVBV 2012-1  
DATE: 8/18 (SU-8)



0. 1/4" = 12' 1" 1/2" = 30' 3/4" = 60' 1 1/2" = 120' 1 1/2" = 240' 1 1/2" = 480' 1 1/2" = 960' 1 1/2" = 1920' 1 1/2" = 3840'

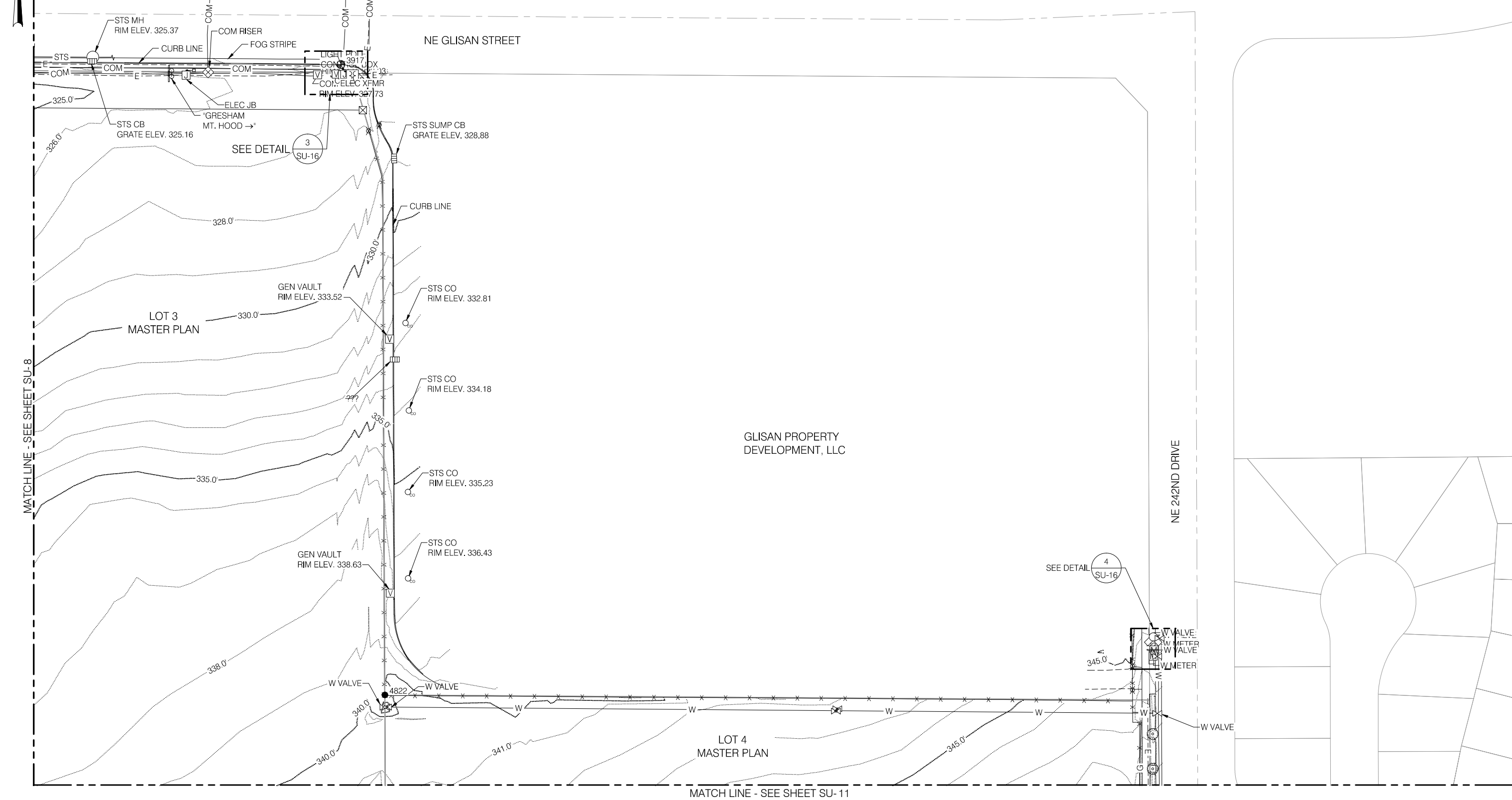
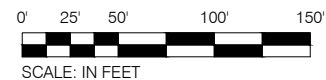

CAN YOU SEE THE AIRPLANES? THE ADJACENT SAMPLES SHOW THREE DIFFERENT LEVELS OF SHADING. SETTINGS FOR VIEWING AND PRINTING DRAWING CONTENT ARE OPTIMIZED WHEN ALL THREE PLANES ARE VISIBLE. THIS GUIDANCE IS PROVIDED FOR REFERENCE ONLY.

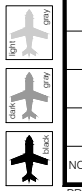

| NO. | DATE | BY | REVISIONS | APP'VD | CKD | NO. | DATE | BY | REVISIONS | APP'VD | CKD |
|-----|------|----|-----------|--------|-----|-----|------|----|-----------|--------|-----|
|     |      |    |           |        |     |     |      |    |           |        |     |



PORT OF PORTLAND  
PORTLAND, OREGON

2012UGEN  
DESIGN NUMBER

101743  
PROJECT NUMBER

REGISTERED  
PROFESSIONAL  
LAND SURVEYOR

OREGON  
JULY 25, 1995  
CHRISTOPHER VANDERWERF  
2719

SIGNED:  
EXP: 6/30/2014

DESIGNED BY: C. VANDERWERF  
DRAWN BY: C. BIELANSKI / P. SHIELDS  
CHECKED BY: C. VANDERWERF  
DATE: SEP 2013  
SCALE: 1" = 50'

GRESHAM VISTA BUSINESS PARK

GVBP TOPOGRAPHIC SURVEY  
LAYOUT 8

SUBMITTED BY: ROBIN MCCAFFREY  
ENGINEERING PROJECT MANAGER

TYPE: TS  
DRAWING NO.: GVBP 2012-1  
9/18 (SU-9)

0 1/4" = 1' GRAPHIC SCALE: PART REFERENCE ONLY

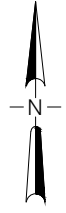

0' 25' 50' 100' 150'  
SCALE: IN FEET

MATCH LINE - SEE SHEET SU-8

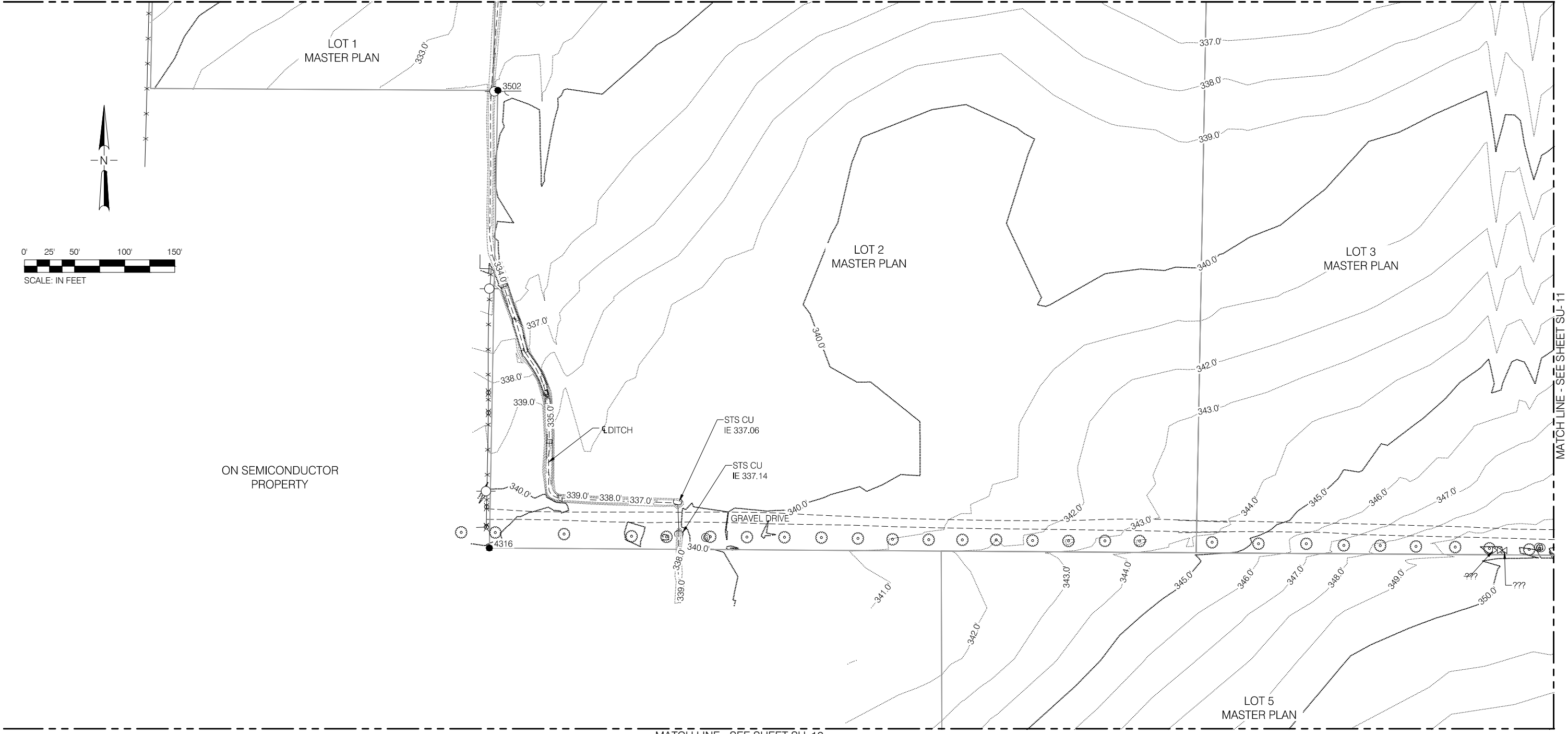

MATCH LINE - SEE SHEET SU-12

MATCH LINE - SEE SHEET SU-11

CAN YOU SEE THE AIRPLANES? THE ADJACENT SAMPLES SHOW THREE DIFFERENT LEVELS OF SHADING. SETTINGS FOR VIEWING AND PRINTING DRAWING CONTENT ARE OPTIMIZED WHEN ALL THREE PLANES ARE VISIBLE. THIS GUIDANCE IS PROVIDED FOR REFERENCE ONLY.



| NO. | DATE | BY | REVISIONS | APP'VD | CKD | NO. | DATE | BY | REVISIONS | APP'VD | CKD |
|-----|------|----|-----------|--------|-----|-----|------|----|-----------|--------|-----|
|     |      |    |           |        |     |     |      |    |           |        |     |



PORT OF PORTLAND  
PORTLAND, OREGON

2012UGEN DESIGN NUMBER      101743 PROJECT NUMBER

REGISTERED PROFESSIONAL LAND SURVEYOR

OREGON JULY 25, 1995 CHRISTOPHER VANDERWERF 2719

SIGNED: EXP: 6/30/2014

DESIGNED BY: C. VANDERWERF  
DRAWN BY: C. BIELANSKI / P. SHIELDS  
CHECKED BY: C. VANDERWERF  
DATE: SEP 2013  
SCALE: 1" = 50'

GRESHAM VISTA BUSINESS PARK

GVBP TOPOGRAPHIC SURVEY LAYOUT 9

SUBMITTED BY: ROBIN MCCAFFREY ENGINEERING PROJECT MANAGER

TYPE: TS      DRAWING NO.: GVBP 2012-1      10/18 (SU-10)

CAN YOU SEE THE AIRPLANES? THE ADJACENT SAMPLES SHOW THREE DIFFERENT LEVELS OF SHADING. SETTINGS FOR VIEWING AND PRINTING DRAWING CONTENT ARE OPTIMIZED WHEN ALL THREE PLANES ARE VISIBLE. THIS GUIDANCE IS PROVIDED FOR REFERENCE ONLY.

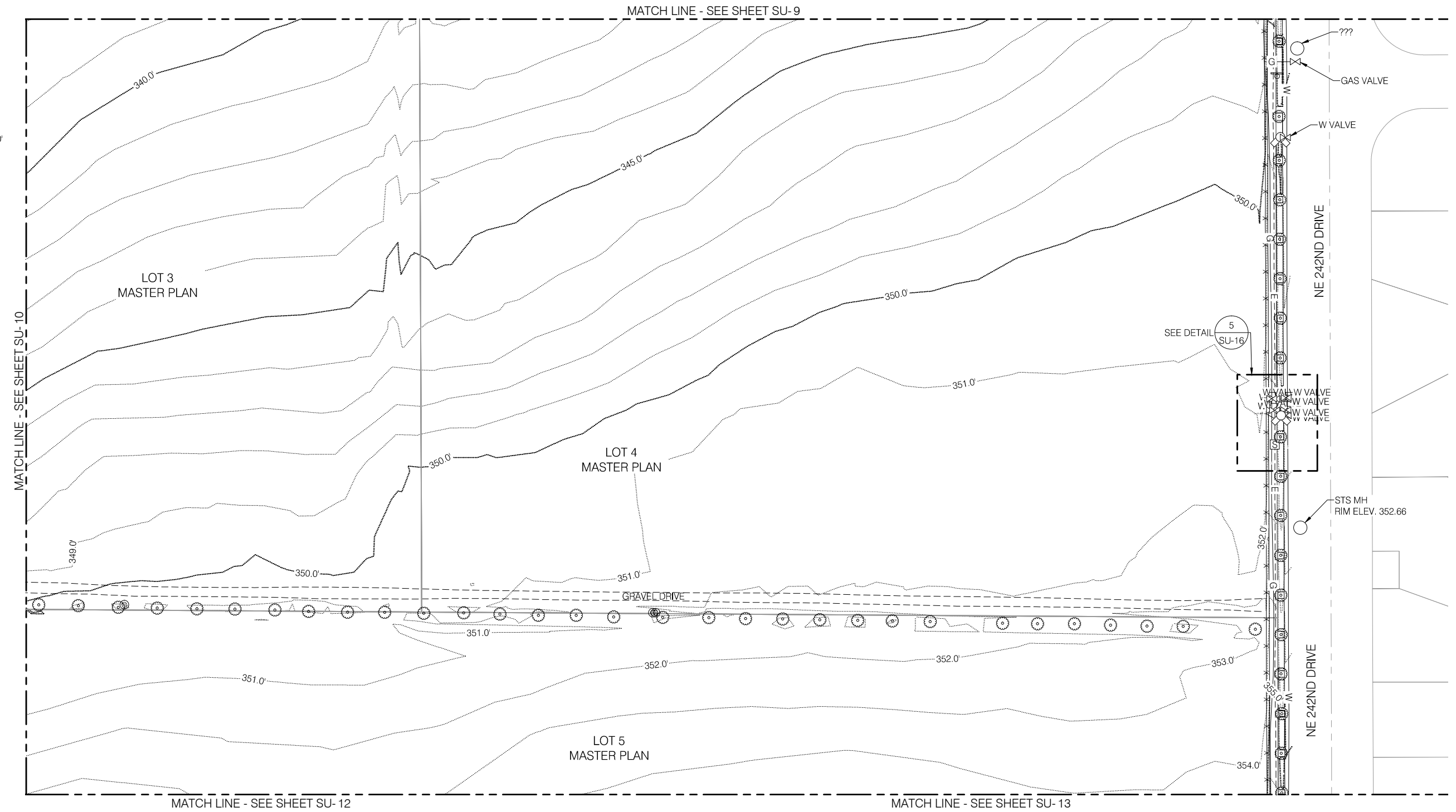
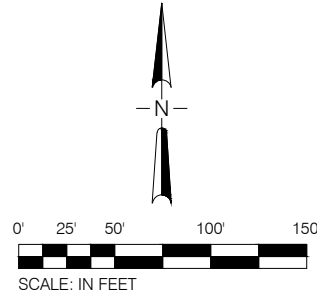

CAN YOU SEE THE AIRPLANES? THE ADJACENT SAMPLES SHOW THREE DIFFERENT LEVELS OF SHADING. SETTINGS FOR VIEWING AND PRINTING DRAWING CONTENT ARE OPTIMIZED WHEN ALL THREE PLANES ARE VISIBLE. THIS GUIDANCE IS PROVIDED FOR REFERENCE ONLY.

| NO. | DATE | BY | REVISIONS | APP'VD | CKD | NO. | DATE | BY | REVISIONS | APP'VD | CKD |
|-----|------|----|-----------|--------|-----|-----|------|----|-----------|--------|-----|
|     |      |    |           |        |     |     |      |    |           |        |     |



**PORT OF PORTLAND**  
 PORTLAND, OREGON

2012UGEN  
DESIGN NUMBER

101743  
PROJECT NUMBER

REGISTERED  
 PROFESSIONAL  
 LAND SURVEYOR

OREGON  
 JULY 25, 1995  
 CHRISTOPHER VANDERWERF  
 2719

SIGNED:  
 EXP: 6/30/2014

DESIGNED BY: C. VANDERWERF  
 DRAWN BY: C. BIELANSKI / P. SHIELDS  
 CHECKED BY: C. VANDERWERF  
 DATE: SEP 2013  
 SCALE: 1" = 50'

**GRESHAM VISTA BUSINESS PARK**  
**GVBP TOPOGRAPHIC SURVEY**  
**LAYOUT 10**

SUBMITTED BY: ROBIN MCCAFFREY  
ENGINEERING PROJECT MANAGER

TYPE: TS  
 DRAWING NO.: GVBP 2012-1  
 DATE: 11/18 (SU-11)

CAN YOU SEE THE AIRPLANES? THE ADJACENT SAMPLES SHOW THREE DIFFERENT LEVELS OF SHADING. SETTINGS FOR VIEWING AND PRINTING DRAWING CONTENT ARE OPTIMIZED WHEN ALL THREE PLANES ARE VISIBLE. THIS GUIDANCE IS PROVIDED FOR REFERENCE ONLY.

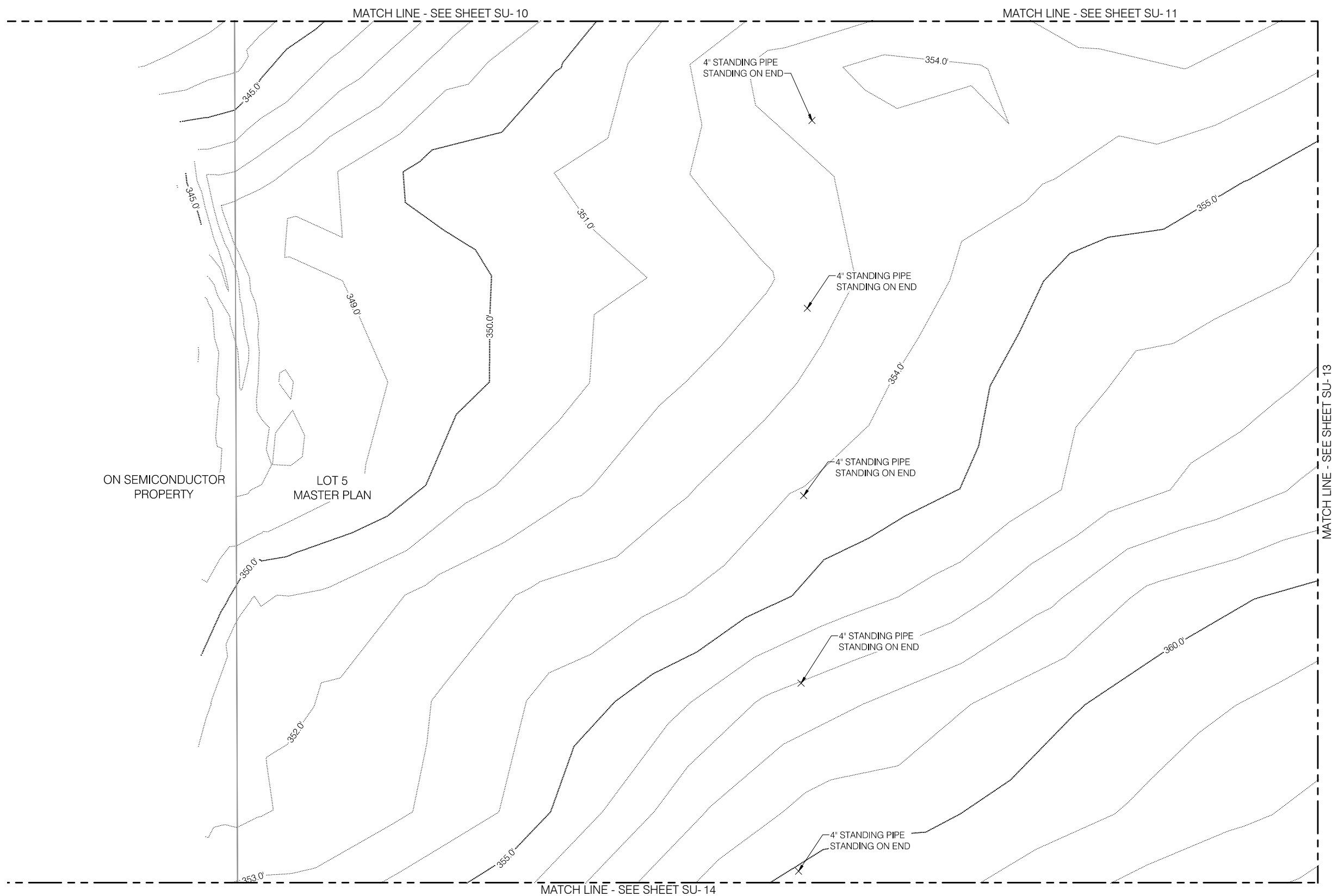
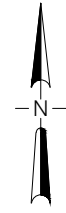

CAN YOU SEE THE AIRPLANES? THE ADJACENT SAMPLES SHOW THREE DIFFERENT LEVELS OF SHADING. SETTINGS FOR VIEWING AND PRINTING DRAWING CONTENT ARE OPTIMIZED WHEN ALL THREE PLANES ARE VISIBLE. THIS GUIDANCE IS PROVIDED FOR REFERENCE ONLY.



| NO. | DATE | BY | REVISIONS | APP'VD | CKD | NO. | DATE | BY | REVISIONS | APP'VD | CKD |
|-----|------|----|-----------|--------|-----|-----|------|----|-----------|--------|-----|
|     |      |    |           |        |     |     |      |    |           |        |     |



**PORT OF PORTLAND**  
PORTLAND, OREGON

2012UGEN  
DESIGN NUMBER

101743  
PROJECT NUMBER

REGISTERED  
PROFESSIONAL  
LAND SURVEYOR

OREGON  
JULY 25, 1995  
CHRISTOPHER VANDERWERF  
2719

SIGNED:  
EXP: 6/30/2014

DESIGNED BY: C. VANDERWERF

DRAWN BY: C. BIELANSKI / P. SHIELDS

CHECKED BY: C. VANDERWERF

DATE: SEP 2013

SCALE: 1" = 50'

**GRESHAM VISTA BUSINESS PARK**

**GVBP TOPOGRAPHIC SURVEY  
LAYOUT 11**

SUBMITTED BY: **ROBIN MCCAFFREY**  
ENGINEERING PROJECT MANAGER

TYPE: TS

DRAWING NO.: GVBP 2012-1

DATE: 12/18 (SU-12)

CAN YOU SEE THE AIRPLANES? THE ADJACENT SAMPLES SHOW THREE DIFFERENT LEVELS OF SHADING. SETTINGS FOR VIEWING AND PRINTING DRAWING CONTENT ARE OPTIMIZED WHEN ALL THREE PLANES ARE VISIBLE. THIS GUIDANCE IS PROVIDED FOR REFERENCE ONLY.

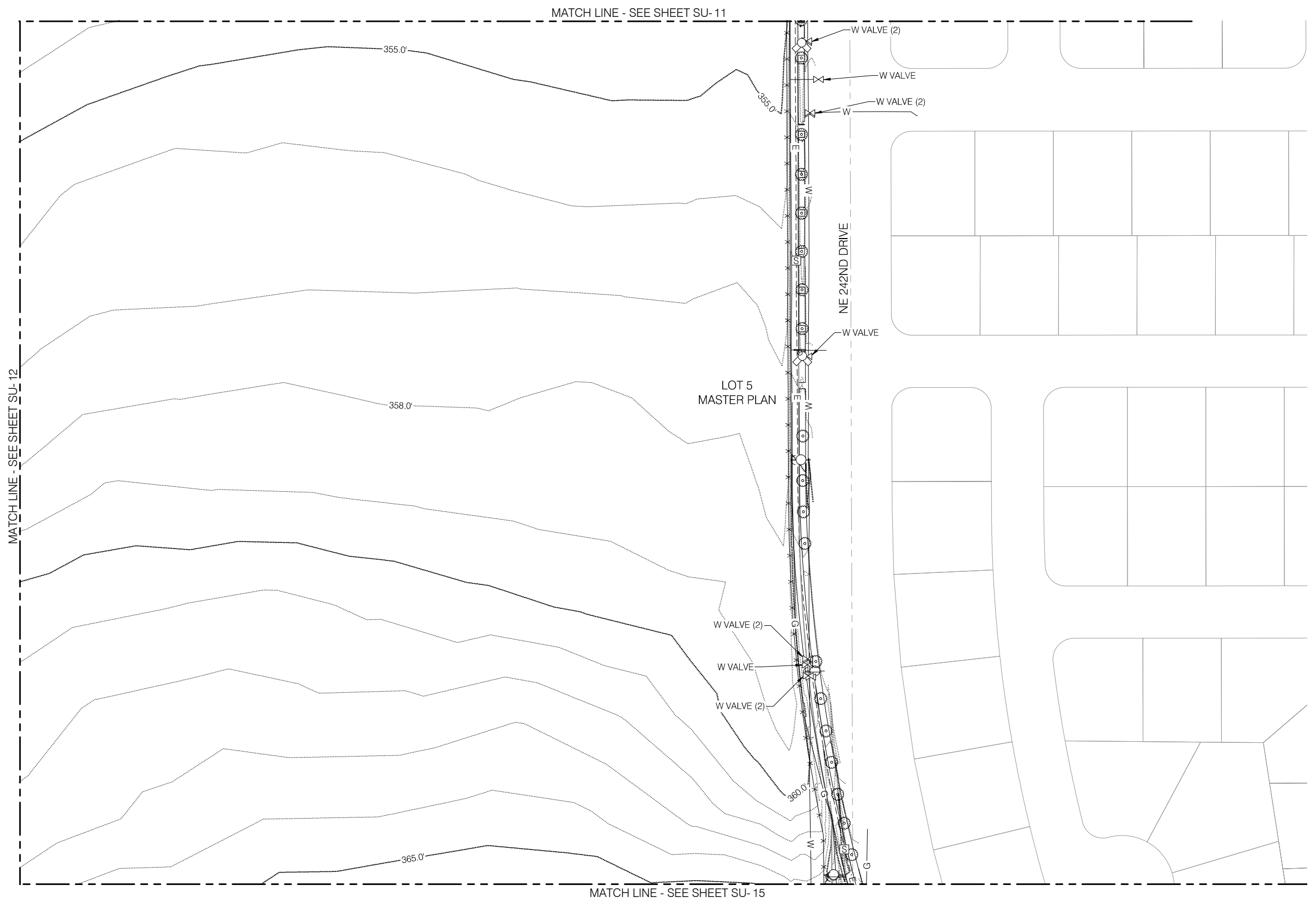
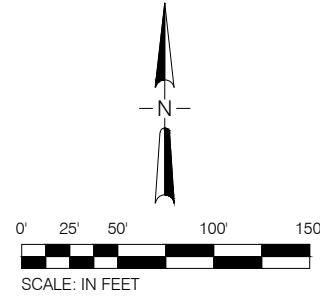

CAN YOU SEE THE AIRPLANES? THE ADJACENT SAMPLES SHOW THREE DIFFERENT LEVELS OF SHADING. SETTINGS FOR VIEWING AND PRINTING DRAWING CONTENT ARE OPTIMIZED WHEN ALL THREE PLANES ARE VISIBLE. THIS GUIDANCE IS PROVIDED FOR REFERENCE ONLY.

| NO. | DATE | BY | REVISIONS | APP'VD | CKD | NO. | DATE | BY | REVISIONS | APP'VD | CKD |
|-----|------|----|-----------|--------|-----|-----|------|----|-----------|--------|-----|
|     |      |    |           |        |     |     |      |    |           |        |     |



**PORT OF PORTLAND**  
PORTLAND, OREGON

2012UGEN      101743  
DESIGN NUMBER      PROJECT NUMBER

REGISTERED PROFESSIONAL LAND SURVEYOR

OREGON  
JULY 25, 1995  
CHRISTOPHER VANDERWERF  
2719

SIGNED: EXP: 6/30/2014

DESIGNED BY: C. VANDERWERF  
DRAWN BY: C. BIELANSKI / P. SHIELDS  
CHECKED BY: C. VANDERWERF  
DATE: SEP 2013  
SCALE: 1" = 50'

**GRESHAM VISTA BUSINESS PARK**

**GVBP TOPOGRAPHIC SURVEY LAYOUT 12**

SUBMITTED BY: **ROBIN MCCAFFREY**  
ENGINEERING PROJECT MANAGER

TYPE: TS      DRAWING NO.: GVBP 2012-1      13/18 (SU-13)

GRAPHIC SCALE: FOR REFERENCE ONLY

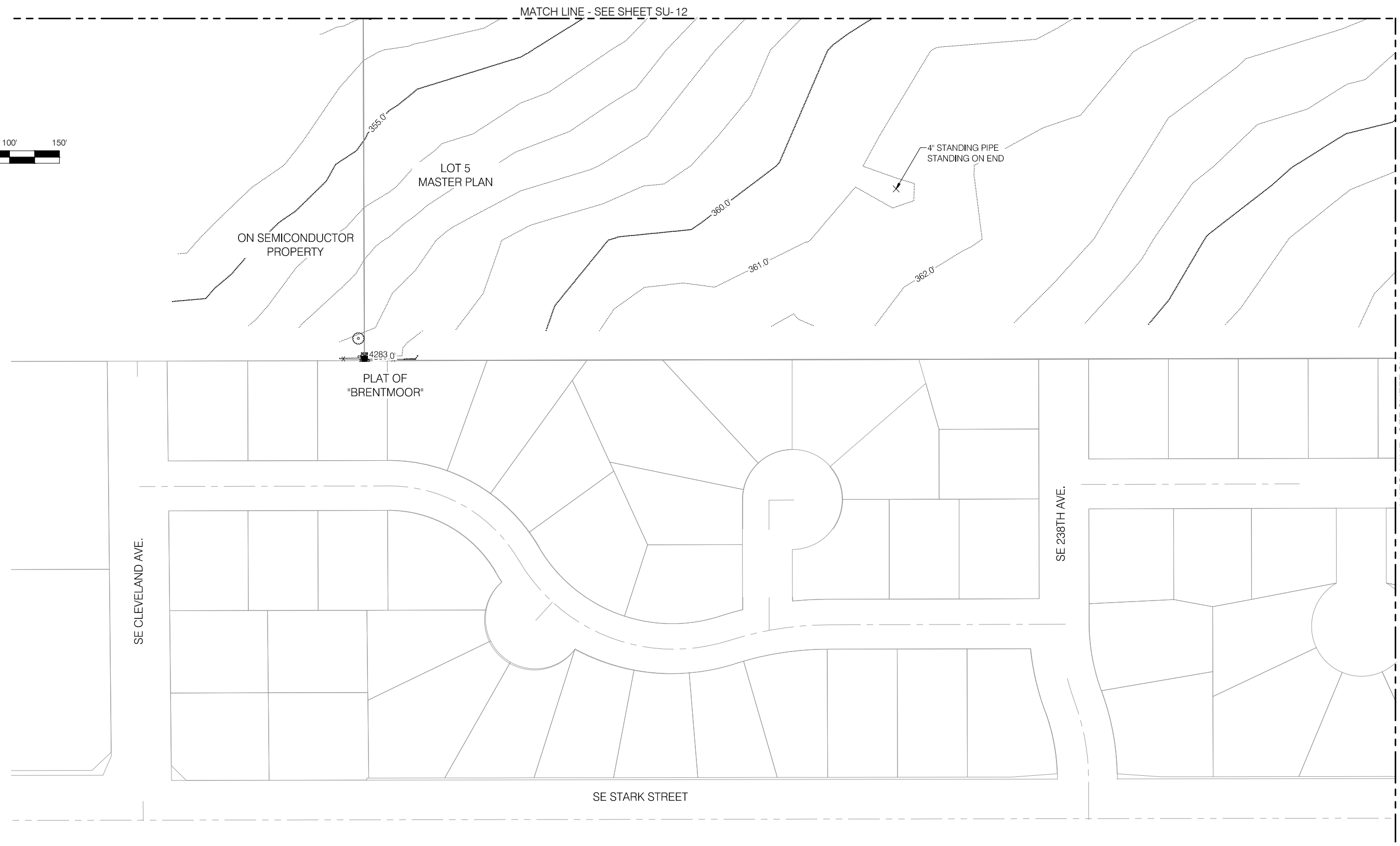
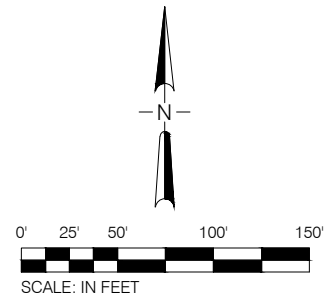

MATCH LINE - SEE SHEET SU-12

MATCH LINE - SEE SHEET SU-15

CAN YOU SEE THE AIRPLANES? THE ADJACENT SAMPLES SHOW THREE DIFFERENT LEVELS OF SHADING. SETTINGS FOR VIEWING AND PRINTING DRAWING CONTENT ARE OPTIMIZED WHEN ALL THREE PLANES ARE VISIBLE. THIS GUIDANCE IS PROVIDED FOR REFERENCE ONLY.

| NO. | DATE | BY | REVISIONS | APP'VD | CKD | NO. | DATE | BY | REVISIONS | APP'VD | CKD |
|-----|------|----|-----------|--------|-----|-----|------|----|-----------|--------|-----|
|     |      |    |           |        |     |     |      |    |           |        |     |

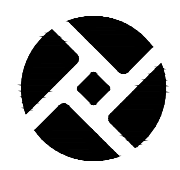

PORT OF PORTLAND  
PORTLAND, OREGON

2012UGEN DESIGN NUMBER      101743 PROJECT NUMBER

REGISTERED PROFESSIONAL LAND SURVEYOR

OREGON  
JULY 25, 1995  
CHRISTOPHER VANDERWERF  
2719  
SIGNED:      EXP: 6/30/2014

DESIGNED BY: C. VANDERWERF  
DRAWN BY: C. BIELANSKI / P. SHIELDS  
CHECKED BY: C. VANDERWERF  
DATE: SEP 2013  
SCALE: 1" = 50'

|  |   |
|--|---|
| GRESHAM VISTA BUSINESS PARK                                  |   |
| GVBP TOPOGRAPHIC SURVEY LAYOUT 13                            |   |
| SUBMITTED BY: ROBIN MCCAFFREY<br>ENGINEERING PROJECT MANAGER | TYPE: TS      DRAWING NO.: GVBP 2012-1      14/18 (SU-14) |

0 1/4" = 1' GRAPHIC SCALE: PART REFERENCE ONLY

MATCH LINE - SEE SHEET SU- 14



MATCH LINE - SEE SHEET SU- 13

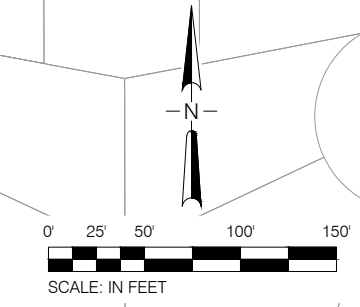

CAN YOU SEE THE AIRPLANES? THE ADJACENT SAMPLES SHOW THREE DIFFERENT LEVELS OF SHADING. SETTINGS FOR VIEWING AND PRINTING DRAWING CONTENT ARE OPTIMIZED WHEN ALL THREE PLANES ARE VISIBLE. THIS GUIDANCE IS PROVIDED FOR REFERENCE ONLY.

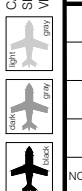

| NO. | DATE | BY | REVISIONS | APP'VD | CKD | NO. | DATE | BY | REVISIONS | APP'VD | CKD |
|-----|------|----|-----------|--------|-----|-----|------|----|-----------|--------|-----|
|     |      |    |           |        |     |     |      |    |           |        |     |



PORT OF PORTLAND  
PORTLAND, OREGON

REGISTERED  
PROFESSIONAL  
LAND SURVEYOR

OREGON  
JULY 25, 1995  
CHRISTOPHER VANDERWERF  
2719

SIGNED:  
EXP: 6/30/2014

2012UGEN DESIGN NUMBER 101743 PROJECT NUMBER

DESIGNED BY C. VANDERWERF  
DRAWN BY C. BIELANSKI / P. SHIELDS  
CHECKED BY C. VANDERWERF  
DATE SEP 2013  
SCALE 1" = 50'

GRESHAM VISTA BUSINESS PARK

GVBP TOPOGRAPHIC SURVEY  
LAYOUT 14

SUBMITTED BY  
ROBIN MCCAFFREY  
ENGINEERING PROJECT MANAGER

TYPE TS DRAWING NO. GVBP 2012-1 15/18 (SU-15)

0 1/4" 1/2" 1" 2" 4" 8" 16" 32"  
 GRAPHIC SCALE: PART REFERENCE ONLY

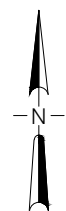

0' 5' 10' 20' 30'  
 SCALE: IN FEET

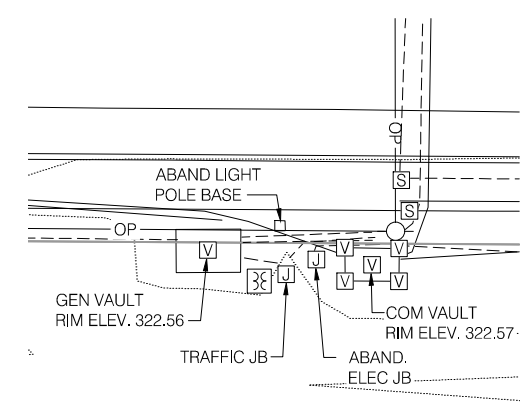

1 DETAIL 1  
 SCALE: 1" = 10'

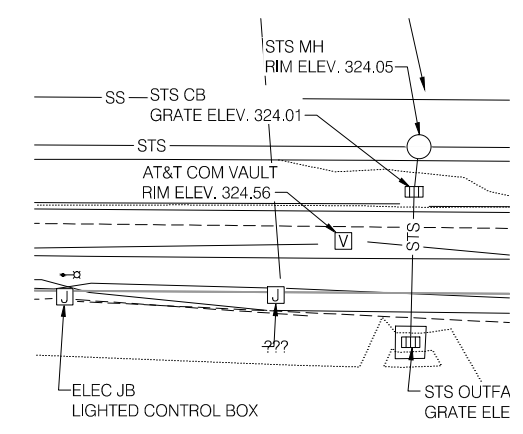

2 DETAIL 2  
 SCALE: 1" = 10'

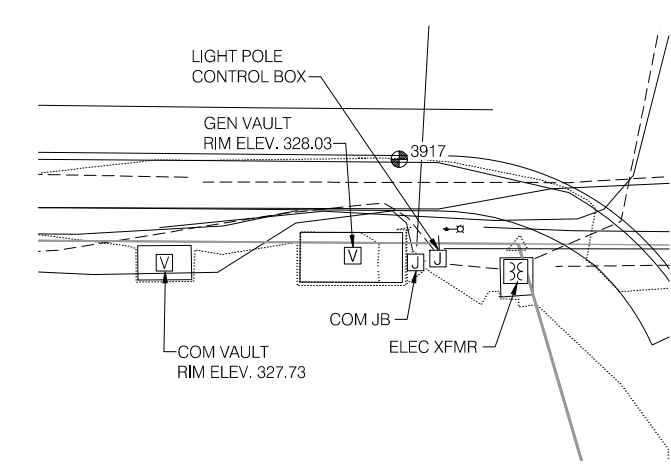

3 DETAIL 3  
 SCALE: 1" = 10'

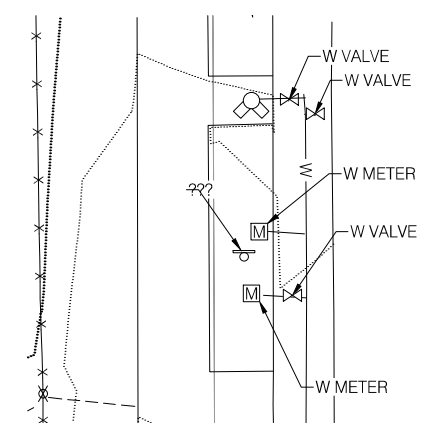

4 DETAIL 4  
 SCALE: 1" = 10'

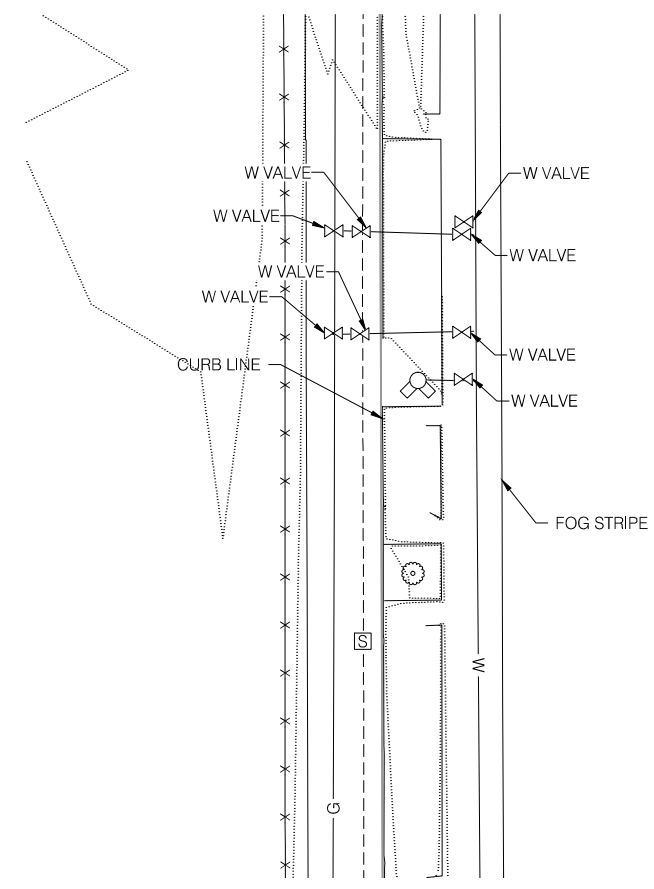

5 DETAIL 5  
 SCALE: 1" = 10'

CAN YOU SEE THE AIRPLANES? THE ADJACENT SAMPLES SHOW THREE DIFFERENT LEVELS OF SHADING. SETTINGS FOR VIEWING AND PRINTING DRAWING CONTENT ARE OPTIMIZED WHEN ALL THREE PLANES ARE VISIBLE. THIS GUIDANCE IS PROVIDED FOR REFERENCE ONLY.



| NO. | DATE | BY | REVISIONS | APP'VD | CKD | NO. | DATE | BY | REVISIONS | APP'VD | CKD |
|-----|------|----|-----------|--------|-----|-----|------|----|-----------|--------|-----|
|     |      |    |           |        |     |     |      |    |           |        |     |



**PORT OF PORTLAND**  
 PORTLAND, OREGON

2012UGEN DESIGN NUMBER      101743 PROJECT NUMBER

REGISTERED PROFESSIONAL LAND SURVEYOR  
 OREGON JULY 25, 1995 CHRISTOPHER VANDERWERF 2719  
 SIGNED: EXP: 6/30/2014

DESIGNED BY: C. VANDERWERF  
 DRAWN BY: C. BIELANSKI / P. SHIELDS  
 CHECKED BY: C. VANDERWERF  
 DATE: SEP 2013  
 SCALE: 1" = 10'

**GRESHAM VISTA BUSINESS PARK**  
 GVBP TOPOGRAPHIC SURVEY  
 DETAILS

SUBMITTED BY: ROBIN MCCAFFREY ENGINEERING PROJECT MANAGER  
 TYPE: TS      DRAWING NO.: GVBP 2012-1      17/18 (SU-17)



0 1/4" 1/2" 1" 2" 4" 8"  
 GRAPHIC SCALE FOR REFERENCE ONLY

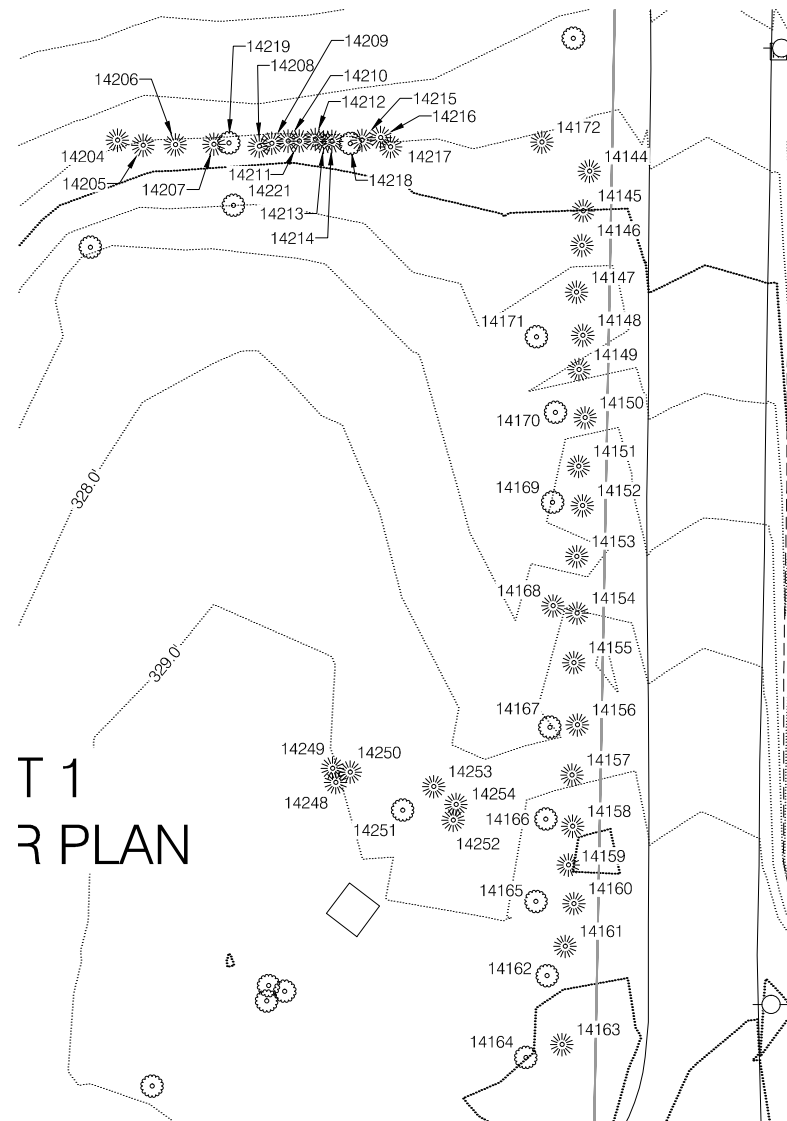
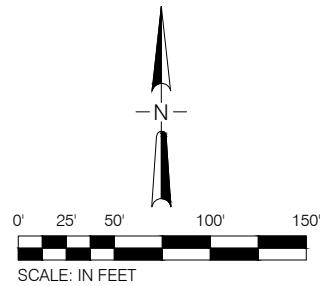

T 1  
R PLAN

1 LOT 1 TREE DETAIL  
SCALE: 1" = 20'

CAN YOU SEE THE AIRPLANES? THE ADJACENT SAMPLES SHOW THREE DIFFERENT LEVELS OF SHADING.  
 SETTINGS FOR VIEWING AND PRINTING DRAWING CONTENT ARE OPTIMIZED WHEN ALL THREE PLANES ARE  
 VISIBLE. THIS GUIDANCE IS PROVIDED FOR REFERENCE ONLY.



| NO. | DATE | BY | REVISIONS | APP'VD | CKD | NO. | DATE | BY | REVISIONS | APP'VD | CKD |
|-----|------|----|-----------|--------|-----|-----|------|----|-----------|--------|-----|
|     |      |    |           |        |     |     |      |    |           |        |     |



PORT OF PORTLAND  
PORTLAND, OREGON

REGISTERED  
PROFESSIONAL  
LAND SURVEYOR

OREGON  
JULY 25, 1995  
CHRISTOPHER VANDERWERF  
2719

SIGNED:  
EXP: 6/30/2014

|             |                           |
|-------------|---------------------------|
| DESIGNED BY | C. VANDERWERF             |
| DRAWN BY    | C. BIELANSKI / P. SHIELDS |
| CHECKED BY  | C. VANDERWERF             |
| DATE        | SEP 2013                  |
| SCALE       | 1" = 20'                  |

GRESHAM VISTA BUSINESS PARK

GVBV TOPOGRAPHIC SURVEY  
TREE DETAIL & TABLES

|              |                 |      |    |             |               |
|--------------|-----------------|------|----|-------------|---------------|
| SUBMITTED BY | ROBIN MCCAFFREY | TYPE | TS | DRAWING NO. | 18/18 (SU-18) |
|              |                 |      |    | GVBV 2012-1 |               |